

Series CS



Tantalum Electrolytic Capacitors Surface Mount Type

FEATURES:

- Lead-Free.
- General purpose surface mount type.
- Compact size & wide CV range.
- High solderability & stable characteristics for soldering.
- Compatible with all popular automatic pick and place equipment.



SPECIFICATION:

Item	Performance Characteristics																						
Operating Temperature Range	-55 to +125°C (>85°C with rated voltage derating)																						
Rated Working Voltage Range	4 to 50 V DC																						
Nominal Capacitance Range	0.1 to 470 μF																						
Capacitance Tolerance	±20% ± 10% (120Hz, +20°C)																						
Leakage Current	Not more than 0.01CV [μA] or 0.5μA whichever is greater																						
tan δ (120Hz, +20°C)	0.04 max. for ≤ 1.0μF																						
	0.06 max. for 1.5 to 68μF																						
	0.08 max. for 100 to 470 μF																						
Characteristics at High and Low Temperature	-55°C	Capacitance change	±12% of initial measured value at +20°C																				
	+105°C	Leakage current	≤12.5% of initial measured value																				
		Capacitance change	±15% of initial measured value at +20°C																				
Moisture Resistance	Test conditions																						
	Relative humidity : 90 to 95% without load Ambient temperature : +40°C Duration : 500 hours Post test requirements at + 20°C Leakage current : ≤ Initial specified value Capacitance change : ± 10% of initial measured value tan δ : ≤ Initial specified value																						
Endurance	Test conditions																						
	<table border="1"> <thead> <tr> <th>Item \ Conditions</th> <th colspan="2">Derating</th> <th>Rating</th> </tr> </thead> <tbody> <tr> <td>Duration</td> <td colspan="2">1000 hours</td> <td>1000 hours</td> </tr> <tr> <td>Ambient temperature</td> <td colspan="2">+ 105°C</td> <td>+ 85°C</td> </tr> <tr> <td>Applied voltage</td> <td colspan="2">Derated working voltage</td> <td>Rated working voltage</td> </tr> <tr> <td>Source impedance</td> <td colspan="2">1Ω/V</td> <td>1Ω/V</td> </tr> </tbody> </table>			Item \ Conditions	Derating		Rating	Duration	1000 hours		1000 hours	Ambient temperature	+ 105°C		+ 85°C	Applied voltage	Derated working voltage		Rated working voltage	Source impedance	1Ω/V		1Ω/V
	Item \ Conditions	Derating		Rating																			
	Duration	1000 hours		1000 hours																			
	Ambient temperature	+ 105°C		+ 85°C																			
	Applied voltage	Derated working voltage		Rated working voltage																			
	Source impedance	1Ω/V		1Ω/V																			
	Derating voltage + 105°C																						
	<table border="1"> <thead> <tr> <th>Working voltage [V] DC</th> <th>4</th> <th>6.3</th> <th>10</th> <th>16</th> <th>20</th> <th>25</th> <th>35</th> <th>50</th> </tr> </thead> <tbody> <tr> <td>Derating voltage [V] DC</td> <td>2.5</td> <td>4</td> <td>6.3</td> <td>10</td> <td>13</td> <td>16</td> <td>22</td> <td>32</td> </tr> </tbody> </table>			Working voltage [V] DC	4	6.3	10	16	20	25	35	50	Derating voltage [V] DC	2.5	4	6.3	10	13	16	22	32		
	Working voltage [V] DC	4	6.3	10	16	20	25	35	50														
Derating voltage [V] DC	2.5	4	6.3	10	13	16	22	32															
Post test requirements at +20°C																							
Leakage current : ≤ 125% of initial specified value																							
Capacitance change : ± 10% of initial measured value																							
tan δ : ≤ Initial specified value																							
Shelf Life	Test conditions		Post test requirements at +20°C																				
	Duration	: 1000 hours	Same limits for "Endurance".																				
	Ambient temperature	: +125°C																					
	Applied voltage	: (none)																					
Solder Heat Resistance	The capacitor shall withstand dipping into solder bath for 5±1 seconds at 260±5°C																						

Series CS

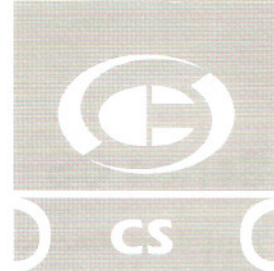

Tantalum Electrolytic Capacitors Surface Mount Type

1. Tantalum Capacitor CHIP TYPE OUTLINE DRAWINGS.

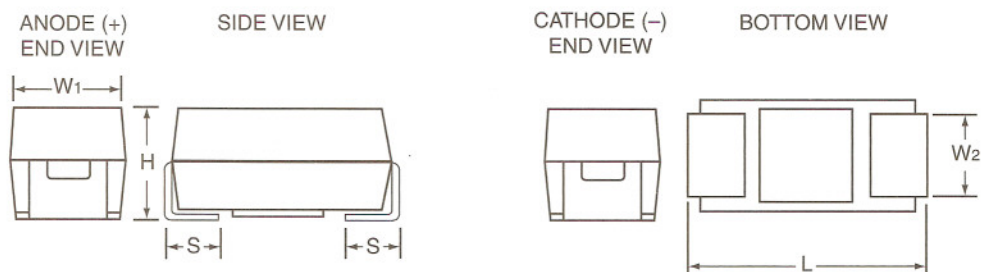

2. Dimensions Millimeters (Inch)

Case Size	$L \pm 0.2$ (0.008)	$W_1 \pm 0.2$ (0.008)	$H \pm 0.2$ (0.008)	$S \pm 0.2$ (0.008)	$W_2 \pm 0.2$ (0.008)
S	2.0 (0.079)	1.2 (0.047)	1.2 (0.047)	0.5 (0.020)	1.2 (0.047)
A	3.2 (0.126)	1.6 (0.063)	1.6 (0.063)	0.8 (0.031)	1.2 (0.047)
B	3.5 (0.137)	2.8 (0.110)	1.9 (0.075)	0.8 (0.031)	2.2 (0.087)
C	6.0 (0.236)	3.2 (0.126)	2.5 (0.098)	1.3 (0.051)	2.2 (0.087)
D	7.3 (0.287)	4.3 (0.169)	2.8 (0.110)	1.3 (0.051)	2.4 (0.094)
E	7.3 (0.287)	4.3 (0.169)	4.0 (0.157)	1.3 (0.051)	2.4 (0.094)

3. Rated Voltage, Capacitance of Capacitors.

Rated Voltage (V)	4	6.3	10	16	20	25	35	50
Code	0G	0J	1A	1C	1D	1E	1V	1H
Capacitance (μF)	Case Size							
0.10 (104)					S		A	A
0.15 (154)					S		A	A/B
0.22 (224)					S		A	B
0.33 (334)					S		A	B
0.47 (474)				S	S	A	A/B	C
0.68 (684)			S	S	S/A	A	A/B	C
1.0 (105)		S/A	S/A	S/A	A	A/B	A/B	C
1.5 (155)	S	S/A	S/A	S/A	A/B	B	B/C	C/D
2.2 (225)	S	S/A	S/A	A/B	A/B	B	B/C	D
3.3 (335)	S/A	S/A	S/A	A/B	A/B/C	B/C	B/C/D	D
4.7 (475)	S/A	S/A	S/A/B	A/B	A/B/C	B/C	C/D	D/E
6.8 (685)	S/A	S/A/B	A/B	A/B/C	B/C/D	C/D	C/D	D
10 (106)	A/B	A/B	A/B	A/B/C	C/D	C/D	C/D	E
15 (156)	A/B	A/B	B/C	B/C	C/D	C/D	E	
22 (226)	A/B	A/B	B/C	B/C/D	C/D	D	E	
33 (336)	B/C	B/C	C/D	C/D	D	D/E		
47 (476)	B/C	B/C	C/D	C/D	D/E	E		
68 (686)	B/C/D	C/D	D	D	D/E			
100 (107)	B/C/D	C/D	C/D	D	E			
150 (157)	C/D	D	E	E				
220 (227)	D	D/E	D/E	E				
330 (337)	E	D/E	E					
470 (477)	E							



CS

Series CS

Tantalum Electrolytic Capacitors Surface Mount Type

Ratings and Part Number Reference

Part No.	Case Size	Capacitance μF	DCL (μA) Max.	DF % Max.	ESR max. (Ω) @ 100kHz
4 volt @ 85°C (2.5 volt, @ 125°C)					
CSS 0G155(#)TR	S	1.5	0.5	6	30
CSS 0G225(#)TR	S	2.2	0.5	6	25
CSS 0G335(#)TR	S	3.3	0.5	6	20
CSA 0G335(#)TR	A	3.3	0.5	6	9
CSS 0G475(#)TR	S	4.7	0.5	6	10
CSA 0G475(#)TR	A	4.7	0.5	6	7.5
CSS 0G685(#)TR	S	6.8	0.5	6	7.0
CSA 0G685(#)TR	A	6.8	0.5	6	6.5
CSA 0G106(#)TR	A	10	0.5	6	6.0
CSB 0G106(#)TR	B	10	0.5	6	4.0
CSA 0G156(#)TR	A	15	0.6	6	4.0
CSB 0G156(#)TR	B	15	0.6	6	3.5
CSA 0G226(#)TR	A	22	0.88	6	3.5
CSB 0G226(#)TR	B	22	0.88	6	3.2
CSB 0G336(#)TR	B	33	1.32	6	2.8
CSC 0G336(#)TR	C	33	1.32	6	2.2
CSB 0G476(#)TR	B	47	1.88	6	2.2
CSC 0G476(#)TR	C	47	1.88	6	1.8
CSB 0G686(#)TR	B	68	2.72	6	3.5
CSC 0G686(#)TR	C	68	2.72	6	1.6
CSD 0G686(#)TR	D	68	2.72	6	1.1
CSB 0G107(#)TR	B	100	4.0	8	2.5
CSD 0G107(#)TR	C	100	4.0	8	1.3
CSD 0G107(#)TR	D	100	4.0	8	0.9
CSC 0G157(#)TR	C	150	6.0	8	0.9
CSD 0G157(#)TR	D	150	6.0	8	0.9
CSD 0G227(#)TR	D	220	8.8	8	0.9
CSE 0G337(#)TR	E	330	13.2	8	0.9
CSE 0G477(#)TR	E	470	18.8	8	0.9
6.3 volt @ 85°C (4 volt, @ 125°C)					
CSS 0J105(#)TR	S	1.0	0.5	4	25
CSA 0J105(#)TR	A	1.0	0.5	4	14
CSS 0J155(#)TR	S	1.5	0.5	6	25
CSA 0J155(#)TR	A	1.5	0.5	6	12
CSS 0J225(#)TR	S	2.2	0.5	6	20
CSA 0J225(#)TR	A	2.2	0.5	6	9.0
CSS 0J335(#)TR	S	3.3	0.5	6	12
CSA 0J335(#)TR	A	3.3	0.5	6	7.0
CSS 0J475(#)TR	S	4.7	0.5	6	7.0
CSA 0J475(#)TR	A	4.7	0.5	6	6.0
CSS 0J685(#)TR	S	6.8	0.5	6	15
CSA 0J685(#)TR	A	6.8	0.5	6	5.0
CSB 0J685(#)TR	B	6.8	0.5	6	4.0
CSA 0J106(#)TR	A	10	0.63	6	4.0
CSB 0J106(#)TR	B	10	0.63	6	3.0
CSA 0J156(#)TR	A	15	0.94	6	4.0
CSB 0J156(#)TR	B	15	0.94	6	3.3
CSA 0J226(#)TR	A	22	1.38	6	3.5
CSC 0J226(#)TR	B	22	1.38	6	2.5
CSB 0J336(#)TR	B	33	2.07	6	2.0
CSC 0J336(#)TR	C	33	2.07	6	1.8
CSB 0J476(#)TR	B	47	2.96	6	2.0
CSC 0J476(#)TR	C	47	2.96	6	1.6
CSC 0J686(#)TR	C	68	4.28	6	1.6
CSD 0J686(#)TR	D	68	4.28	6	0.9
CSC 0J107(#)TR	C	100	6.3	8	1.4
CSD 0J107(#)TR	D	100	6.3	8	0.9
CSD 0J157(#)TR	D	150	9.45	8	0.9
CSD 0J227(#)TR	D	220	13.86	8	0.7
CSE 0J227(#)TR	E	220	13.86	8	0.9
CSD 0J337(#)TR	D	330	20.79	8	0.5
CSE 0J337(#)TR	E	330	20.79	8	0.9

Part No.	Case Size	Capacitance μF	DCL (μA) Max.	DF % Max.	ESR max. (Ω) @ 100kHz
10 volt @ 85°C (6.3 volt, @ 125°C)					
CSS 1A684(#)TR	S	0.68	0.5	4	30
CSS 1A105(#)TR	S	1.0	0.5	4	25
CSA 1A105(#)TR	A	1.0	0.5	4	13
CSS 1A155(#)TR	S	1.5	0.5	6	25
CSA 1A155(#)TR	A	1.5	0.5	6	10
CSA 1A225(#)TR	S	2.2	0.5	6	15
CSS 1A225(#)TR	A	2.2	0.5	6	7.0
CSA 1A335(#)TR	S	3.3	0.5	6	10
CSS 1A335(#)TR	A	3.3	0.5	6	5.5
CSS 1A475(#)TR	S	4.7	0.5	6	15
CSA 1A475(#)TR	A	4.7	0.5	6	5.0
CSB 1A475(#)TR	B	4.7	0.5	6	4.0
CSA 1A685(#)TR	A	6.8	0.68	6	4.0
CSB 1A685(#)TR	B	6.8	0.68	6	3.0
CSA 1A106(#)TR	A	10	1.0	6	3.0
CSB 1A106(#)TR	B	10	1.0	6	2.5
CSB 1A156(#)TR	B	15	1.5	6	2.8
CSC 1A156(#)TR	C	15	1.5	6	2.2
CSB 1A226(#)TR	B	22	2.2	6	2.4
CSC 1A226(#)TR	C	22	2.2	6	1.8
CSC 1A336(#)TR	C	33	3.3	6	1.6
CSD 1A336(#)TR	D	33	3.3	6	1.1
CSC 1A476(#)TR	C	47	4.7	6	1.2
CSD 1A476(#)TR	D	47	4.7	6	0.9
CSD 1A686(#)TR	D	68	6.8	6	0.9
CSC 1A107(#)TR	C	100	10.0	6	1.3
CSD 1A107(#)TR	D	100	10.0	6	0.9
CSE 1A157(#)TR	E	150	15	8	0.9
CSD 1A227(#)TR	D	220	22	8	0.5
CSE 1A227(#)TR	E	220	22	8	0.9
CSE 1A337(#)TR	E	330	33	8	0.9
16 volt @ 85°C (10 volt, @ 125°C)					
CSS 1C474(#)TR	S	0.47	0.5	4	25.0
CSS 1C684(#)TR	S	0.68	0.5	4	25.0
CSS 1C105(#)TR	S	1.0	0.5	6	20.0
CSA 1C105(#)TR	A	1.0	0.5	6	11.0
CSS 1C155(#)TR	S	1.5	0.5	6	12.0
CSA 1C155(#)TR	A	1.5	0.5	6	8.0
CSA 1C225(#)TR	A	2.2	0.5	6	6.5
CSB 1C225(#)TR	B	2.2	0.5	6	5.5
CSA 1C335(#)TR	A	3.3	0.52	6	5.0
CSB 1C335(#)TR	B	3.3	0.52	6	4.5
CSA 1C475(#)TR	A	4.7	0.75	6	4.0
CSB 1C475(#)TR	B	4.7	0.75	6	3.5
CSA 1C685(#)TR	A	6.8	1.08	6	5.0
CSB 1C685(#)TR	B	6.8	1.08	6	3.5
CSC 1C685(#)TR	C	6.8	1.08	6	2.5
CSA 1C106(#)TR	A	10	1.6	6	5.0
CSB 1C106(#)TR	B	10	1.6	6	2.8
CSC 1C106(#)TR	C	10	1.6	6	2.0
CSB 1C156(#)TR	B	15	2.4	6	3.0
CSC 1C156(#)TR	C	15	2.4	6	1.8
CSB 1C226(#)TR	B	22	3.52	6	2.8
CSC 1C226(#)TR	C	22	3.52	6	1.6
CSD 1C226(#)TR	D	22	3.52	6	1.1
CSC 1C336(#)TR	C	33	5.28	6	1.5
CSD 1C336(#)TR	D	33	5.28	6	0.9
CSC 1C476(#)TR	C	47	7.52	6	1.4
CSD 1C476(#)TR	D	47	7.52	6	0.9
CSD 1C686(#)TR	D	68	10.88	6	0.9
CSD 1C107(#)TR	D	100	16	8	0.9
CSE 1C157(#)TR	E	150	24	8	0.9
CSE 1C227(#)TR	E	220	35.2	8	0.9

Series CS



Tantalum Electrolytic Capacitors Surface Mount Type

Ratings and Part Number Reference

Part No.	Case Size	Capacitance μF	DCL (μA) Max.	DF % Max.	ESR max. (Ω) @ 100kHz
20 volt @ 85°C (13 volt, @ 125°C)					
CSS 1D104(#)TR	S	0.1	0.5	4	25.0
CSS 1D154(#)TR	S	0.15	0.5	4	25.0
CSS 1D224(#)TR	S	0.22	0.5	4	25.0
CSS 1D334(#)TR	S	0.33	0.5	4	25.0
CSS 1D474(#)TR	S	0.47	0.5	4	25.0
CSS 1D684(#)TR	S	0.68	0.5	4	25.0
CSA 1D684(#)TR	A	0.68	0.5	4	12.0
CSA 1D105(#)TR	A	1.0	0.5	4	9.0
CSA 1D155(#)TR	A	1.5	0.5	6	6.5
CSB 1D155(#)TR	B	1.5	0.5	6	5.0
CSA 1D225(#)TR	A	2.2	0.5	6	5.3
CSB 1D225(#)TR	B	2.2	0.5	6	3.5
CSA 1D335(#)TR	A	3.3	0.66	6	7.0
CSB 1D335(#)TR	B	3.3	0.66	6	3.0
CSC 1D335(#)TR	C	3.3	0.66	6	2.5
CSA 1D475(#)TR	A	4.7	0.94	6	6.0
CSB 1D475(#)TR	B	4.7	0.94	6	3.0
CSC 1D475(#)TR	C	4.7	0.94	6	2.8
CSB 1D685(#)TR	B	6.8	1.36	6	3.5
CSC 1D685(#)TR	C	6.8	1.36	6	2.0
CSD 1D685(#)TR	D	6.8	1.36	6	1.8
CSB 1D106(#)TR	B	10	2.0	6	3.0
CSC 1D106(#)TR	C	10	2.0	6	1.8
CSD 1D106(#)TR	D	10	2.0	6	1.3
CSC 1D156(#)TR	C	15	3.0	6	1.7
CSD 1D156(#)TR	D	15	3.0	6	1.1
CSD 1D226(#)TR	D	22	4.4	6	0.9
CSD 1D336(#)TR	D	33	6.6	6	0.9
CSD 1D476(#)TR	D	47	9.4	6	0.9
CSE 1D476(#)TR	E	47	9.4	6	0.9
CSD 1D686(#)TR	D	68	13.6	6	0.7
CSE 1D686(#)TR	E	68	13.6	6	0.9
CSE 1D107(#)TR	E	100	20.0	8	0.5
25 volt @ 85°C (16 volt, @ 125°C)					
CSA 1E474(#)TR	A	0.47	0.5	4	14.0
CSA 1E684(#)TR	A	0.68	0.5	4	10.0
CSA 1E105(#)TR	A	1.0	0.5	4	8.0
CSB 1E105(#)TR	B	1.0	0.5	4	7.0
CSB 1E155(#)TR	B	1.5	0.5	6	5.0
CSB 1E225(#)TR	B	2.2	0.55	6	4.5
CSB 1E335(#)TR	B	3.3	0.82	6	4.0
CSC 1E335(#)TR	C	3.3	0.82	6	2.8
CSB 1E475(#)TR	B	4.7	1.17	6	3.5
CSC 1E475(#)TR	C	4.7	1.7	6	2.4
CSC 1E685(#)TR	C	6.8	1.7	6	2.0
CSD 1E685(#)TR	D	6.8	1.7	6	1.4
CSC 1E106(#)TR	C	10	2.5	6	1.8
CSD 1E106(#)TR	D	10	2.5	6	1.2
CSC 1E156(#)TR	C	15	3.75	6	1.2
CSD 1E156(#)TR	D	15	3.75	6	1.0
CSD 1E226(#)TR	D	22	5.5	6	0.9
CSD 1E336(#)TR	D	33	8.25	6	0.7
CSE 1E336(#)TR	E	33	8.25	6	0.9
CSE 1E476(#)TR	E	47	11.8	6	0.6

Part No.	Case Size	Capacitance μF	DCL (μA) Max.	DF % Max.	ESR max. (Ω) @ 100kHz
35 volt @ 85°C (22 volt, @ 125°C)					
CSA 1V104(#)TR	A	0.1	0.5	4	24.0
CSA 1V154(#)TR	A	0.15	0.5	4	21.0
CSA 1V224(#)TR	A	0.22	0.5	4	18.0
CSA 1V334(#)TR	A	0.33	0.5	4	15.0
CSA 1V474(#)TR	A	0.47	0.5	4	12.0
CSB 1V474(#)TR	B	0.47	0.5	4	10.0
CSA 1V684(#)TR	A	0.68	0.5	4	10.0
CSB 1V684(#)TR	B	0.68	0.5	4	8.0
CSA 1V105(#)TR	A	1.0	0.5	4	10.0
CSB 1V105(#)TR	B	1.0	0.5	4	6.5
CSB 1V155(#)TR	B	1.5	0.5	6	5.2
CSC 1V155(#)TR	C	1.5	0.52	6	4.5
CSB 1V225(#)TR	B	2.2	0.77	6	4.0
CSC 1V225(#)TR	C	2.2	0.77	6	3.5
CSB 1V335(#)TR	B	3.3	1.15	6	3.0
CSC 1V335(#)TR	C	3.3	1.15	6	2.5
CSD 1V335(#)TR	D	3.3	1.15	6	2.0
CSC 1V475(#)TR	C	4.7	1.64	6	2.2
CSD 1V475(#)TR	D	4.7	1.64	6	1.5
CSC 1V685(#)TR	C	6.8	2.38	6	2.0
CSD 1V685(#)TR	D	6.8	2.38	6	1.3
CSC 1V106(#)TR	C	10	3.50	6	1.2
CSD 1V106(#)TR	D	10	3.50	6	1.0
CSE 1V156(#)TR	E	15	5.25	6	0.9
CSE 1V226(#)TR	E	22	7.70	6	0.9
50 volt @ 85°C (32 volt, @ 125°C)					
CSA 1H104(#)TR	A	0.1	0.5	4	22.0
CSA 1H154(#)TR	A	0.15	0.5	4	17.0
CSB 1H154(#)TR	B	0.15	0.5	4	15.0
CSB 1H224(#)TR	B	0.22	0.5	4	14.0
CSB 1H334(#)TR	B	0.33	0.5	4	12.0
CSC 1H474(#)TR	C	0.47	0.5	4	8.0
CSC 1H684(#)TR	C	0.68	0.5	4	7.0
CSC 1H105(#)TR	C	1.0	0.5	4	5.5
CSC 1H155(#)TR	C	1.5	0.75	6	4.5
CSD 1H155(#)TR	D	1.5	0.75	6	4.0
CSD 1H225(#)TR	D	2.2	1.1	6	2.5
CSD 1H335(#)TR	D	3.3	1.65	6	2.0
CSD 1H475(#)TR	D	4.7	2.35	6	1.5
CSE 1H475(#)TR	E	4.7	2.35	6	1.4
CSE 1H685(#)TR	E	6.8	3.4	6	0.9
CSE 1H106(#)TR	E	10	5.0	6	0.8

All technical data relates to an ambient temperature of +20°C measured at 120 Hz, 0.5V RMS unless otherwise stated.

Insert tolerance, K for ±10% and M for ±20%.

For 10% tolerance, insert, "K" in (#) above.
For 20% tolerance, insert, "M" in (#) above.



CS

Series CS

Tantalum Electrolytic Capacitors Surface Mount Type

CARRIER TAPE PACKAGING SPECIFICATIONS EXPLANATION OF PART NUMBERS

<u>C S</u>	<u>A</u>	<u>O G</u>	<u>4 7 5</u>	<u>M</u>	<u>T</u>	<u>R</u>
Series Code	Case Size	Rated Voltage	Nominal Capacitance	Capacitance Tolerance	Carrier Tape Packaging	Polarity Orientation

Dimensions of the carrier tape and standard parts quantity per reel.

Dimensions

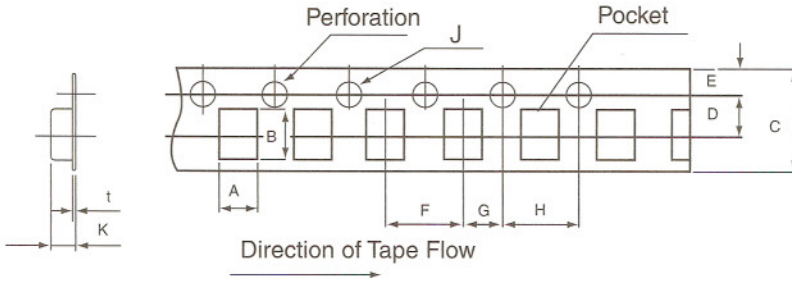

(Unit:mm)

CASE SIZE	A ±0.1	B ±0.1	C ±0.3	D ±0.1	E ±0.1	F ±0.1	G ±0.1	H ±0.1	J +0.1 -0	K MAX	t	Quantity Per Reel
S	1.6	2.4	8.0	3.5	1.75	4.0	2.0	4.0	1.5	2.5	0.2	2500
A	1.9	3.5	8.0	3.5	1.75	4.0	2.0	4.0	1.5	2.5	0.2	2000
B	3.1	3.8	8.0	3.5	1.75	4.0	2.0	4.0	1.5	2.5	0.2	2000
C	3.6	6.4	12.0	5.5	1.75	8.0	2.0	4.0	1.5	3.0	0.3	500
D	4.7	7.7	12.0	5.5	1.75	8.0	2.0	4.0	1.5	3.4	0.3	500
E	4.6	7.6	12.0	5.5	1.75	8.0	2.0	4.0	1.5	4.6	0.3	500

Inserting Direction (Polarity Orientation)

Polarity L: To be inserted with the positive side to the feed hole.

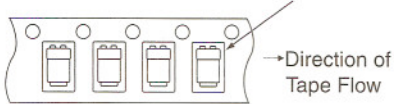

Polarity R: To be inserted with the negative side to the feed hole.

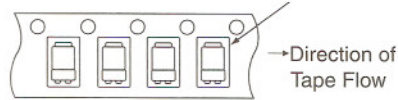

Reel Dimensions

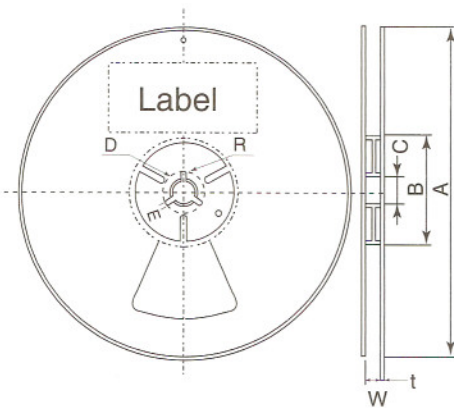

(Unit:mm)

Tape width	8	12
A ₃ ⁰	∅ 180	←
B ₀ ⁺¹	∅ 60	←
C ± 0.2	∅ 13	←
D ± 0.8	∅ 21	←
E ± 0.5	2.0	←
W ± 0.3	9.0	13.0
t ± 0.4	1.3	←
R ± 0.4	10.5	←

Tape Leader and Tailer

